

EC

系列
SERIES

 105°C 自立型長壽命
 壽命：105°C 3000 小時

 105°C LONG LIFE SNAP-IN
 Load Life :105°C 3000 hours

規格表 SPECIFICATIONS

項目 Items	特性 Characteristics														
使用溫度範圍 Category Temperature Range	-40~+105°C							-25~+105°C							
額定電壓範圍 Rated Voltage Range	10~100V.DC							160~450V.DC							
靜電容量容許差 Capacitance Tolerance	±20%(M)(25°C, 120Hz)														
洩漏電流 Leakage Current (MAX)	$I \leq 0.03CV$ (施加額定電壓 5 分鐘後) (After 5 minutes application of rated voltage) I : 洩漏電流 Leakage Current(μA) C : 額定靜電容量 Rated Capacitance(μF) V : 額定電壓 Rated Voltage(V)														
散逸因素($\tan \delta$) Dissipation Factor (MAX)	額定電壓(V) Rated Voltage	10	16	25	35	50	63	100	160	200	250	350	400	450	120Hz 25°C
	$\tan \delta$	0.55	0.45	0.35	0.30	0.25	0.25	0.20	0.15	0.15	0.15	0.20	0.20	0.20	
高溫負荷 Load Life	105°C 恆溫施加額定電壓(含紋波電流)3000 小時後，必須滿足下列的值。 After applying rated voltage with rated ripple current for 3000hrs at 105°C, the capacitors shall meet the following requirements.														
	靜電容量變化率 Capacitance Change	初期值±25%以內 Within ±25% of the initial value													
	散逸因素($\tan \delta$) Dissipation Factor	規格值 200%以下 Not more than 200% of the specified value													
	洩漏電流 Leakage Current	規格值以下 Not more than the specified value													
高溫放置 Shelf Life	105°C 恆溫不施加額定電壓 1000 小時後，必須滿足下列的值。 After applying no rated voltage for 1000hrs at 105°C, The capacitors shall meet the following requirements.														
	靜電容量變化率 Capacitance Change	初期值±20%以內 Within ±20% of the initial value													
	散逸因素($\tan \delta$) Dissipation Factor	規格值 200%以下 Not more than 200% of the specified value													
	洩漏電流 Leakage Current	規格值 200%以下 Not more than 200% of the specified value													
突波電壓(V) Surge Voltage	額定電壓(V) Rated Voltage	10	16	25	35	50	63	100	160	200	250	350	400	450	
	突波電壓(V) Surge Voltage	13	20	32	44	63	79	125	200	250	300	400	450	500	
低溫特性 Low Temperature Stability (合成阻抗比) Impedance Ratio (MAX)	額定電壓(V) Rated Voltage	10	16	25	35	50	63~100		160~250		350~450			120Hz	
	$Z(-25^\circ C) / Z(25^\circ C)$	8	6	6	6	4	3		4		6				
	$Z(-40^\circ C) / Z(25^\circ C)$	15	15	15	10	8	6		-		-				

尺寸圖 DIMENSIONS

(mm)

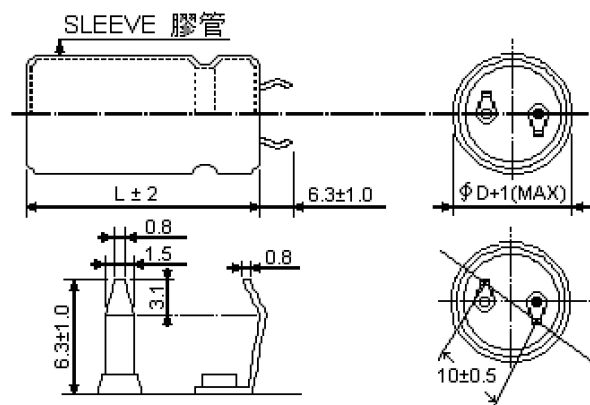
紋波電流補償係數 MULTIPLIER FOR RIPPLE CURRENT

(1) 頻率係數 Frequency coefficient

頻率(Hz) Frequency		60	120	1k	10k	100k
係數 Coefficient	10~35V	0.90	1.00	1.05	1.10	1.10
	50~100V	0.90	1.00	1.15	1.20	1.20
	160~250V	0.80	1.00	1.35	1.45	1.50
	315~450V	0.80	1.00	1.10	1.15	1.20

■ 尺寸一覽表，額定紋波電流一覽表 STANDARD SIZE, RATED RIPPLE CURRENT

Size ϕ D \times L(mm), Ripple Current (A r.m.s./105°C, 120 Hz)

額定電壓 WV(V.DC)	10 (1A)								額定電壓 WV(V.DC)	16 (1C)								
	ϕ 22		ϕ 25		ϕ 30		ϕ 35			ϕ 22		ϕ 25		ϕ 30		ϕ 35		
	Size	Ripple	Size	Ripple	Size	Ripple	Size	Ripple		Size	Ripple	Size	Ripple	Size	Ripple	Size	Ripple	
18000	22 \times 30	2.90								12000	22 \times 30	2.90						
22000	22 \times 35	3.20								15000	22 \times 35	3.20						
27000	22 \times 40	3.40	25 \times 30	3.40						18000	22 \times 40	3.40	25 \times 30	3.40				
33000	22 \times 45	4.10	25 \times 35	4.10						22000	22 \times 45	4.10	25 \times 35	4.10				
39000	22 \times 50	4.40	25 \times 40	4.40	30 \times 30	4.40				27000	22 \times 50	4.40	25 \times 40	4.40	30 \times 30	4.40		
47000			25 \times 45	4.80	30 \times 35	4.80	35 \times 30	5.20		33000			25 \times 45	4.80	30 \times 35	4.80		
56000			25 \times 50	5.20	30 \times 40	5.20	35 \times 35	5.90		39000			25 \times 50	5.20	30 \times 40	5.20	35 \times 30	5.20
68000					30 \times 45	5.90	35 \times 40	6.10		47000					30 \times 45	5.90	35 \times 35	5.90
82000					30 \times 50	6.10	35 \times 45	7.20		56000					30 \times 50	6.10	35 \times 40	6.10
100000							35 \times 50	7.60		68000							35 \times 45	7.20
										82000							35 \times 50	7.60

額定電壓 WV(V.DC)	25 (1E)								額定電壓 WV(V.DC)	35 (1V)								
	ϕ 22		ϕ 25		ϕ 30		ϕ 35			ϕ 22		ϕ 25		ϕ 30		ϕ 35		
	Size	Ripple	Size	Ripple	Size	Ripple	Size	Ripple		Size	Ripple	Size	Ripple	Size	Ripple	Size	Ripple	
8200	22 \times 30	2.90								5600	22 \times 30	2.90						
10000	22 \times 35	3.20	25 \times 30	3.40						6800	22 \times 35	3.20	25 \times 30	3.40				
12000	22 \times 40	3.40	25 \times 35	4.10						8200	22 \times 40	3.40	25 \times 35	4.10				
15000	22 \times 45	4.10	25 \times 40	4.40						10000	22 \times 45	4.10	25 \times 40	4.40	30 \times 30	4.40		
18000	22 \times 50	4.40	25 \times 45	4.80	30 \times 30	4.40				12000	22 \times 50	4.40	25 \times 45	4.80	30 \times 35	4.80		
22000			25 \times 50	5.20	30 \times 35	4.80	35 \times 30	5.20		15000			25 \times 50	5.20	30 \times 40	5.20	35 \times 30	5.20
27000					30 \times 40	5.20	35 \times 35	5.90		18000					30 \times 45	5.90	35 \times 35	5.90
33000					30 \times 45	5.90	35 \times 40	6.10		22000					30 \times 50	6.10	35 \times 40	6.10
39000					30 \times 50	6.10	35 \times 45	7.20		27000							35 \times 45	7.20
47000							35 \times 50	7.60		33000							35 \times 50	7.60

■ 尺寸一覽表，額定紋波電流一覽表 STANDARD SIZE, RATED RIPPLE CURRENT

Size ϕ D \times L(mm), Ripple Current (A r.m.s./105°C, 120 Hz)

額定電壓 WV(V.DC)	50 (1H)								額定電壓 WV(V.DC)	63 (1J)							
	ϕ 22		ϕ 25		ϕ 30		ϕ 35			ϕ 22		ϕ 25		ϕ 30		ϕ 35	
	Size	Ripple	Size	Ripple	Size	Ripple	Size	Ripple		Size	Ripple	Size	Ripple	Size	Ripple	Size	Ripple
3300	22 \times 30	2.90							1800	22 \times 30	2.20						
3900	22 \times 35	3.20							2200	22 \times 35	2.90						
4700	22 \times 40	3.40	25 \times 30	3.40					2700	22 \times 40	3.30	25 \times 30	2.90				
5600	22 \times 45	4.10	25 \times 35	4.10					3300	22 \times 45	3.90	25 \times 35	3.30				
6800	22 \times 50	4.40	25 \times 40	4.40	30 \times 30	4.40			3900	22 \times 50	4.20	25 \times 40	4.20	30 \times 30	4.20		
8200			25 \times 45	4.80	30 \times 35	4.80			4700			25 \times 45	4.60	30 \times 35	4.60		
10000			25 \times 50	5.20	30 \times 40	5.20	35 \times 30	5.20	5600			25 \times 50	5.20	30 \times 40	5.20	35 \times 30	4.60
12000					30 \times 45	5.90	35 \times 35	5.90	6800					30 \times 45	5.50	35 \times 35	5.70
15000					30 \times 50	6.10	35 \times 40	6.10	8200					30 \times 50	5.70	35 \times 40	5.90
18000							35 \times 45	7.20	10000							35 \times 45	6.60
22000							35 \times 50	7.60	12000							35 \times 50	7.40

額定電壓 WV(V.DC)	100 (2A)								額定電壓 WV(V.DC)	160 (2C)							
	ϕ 22		ϕ 25		ϕ 30		ϕ 35			ϕ 22		ϕ 25		ϕ 30		ϕ 35	
	Size	Ripple	Size	Ripple	Size	Ripple	Size	Ripple		Size	Ripple	Size	Ripple	Size	Ripple	Size	Ripple
820	22 \times 30	1.50							390	22 \times 30	0.95						
1000	22 \times 35	1.70							470	22 \times 35	1.10						
1200	22 \times 40	1.80	25 \times 30	1.80					560	22 \times 40	1.30	25 \times 30	1.30				
1500	22 \times 45	2.50	25 \times 35	2.50					680	22 \times 45	1.50	25 \times 35	1.50				
1800	22 \times 50	2.70	25 \times 40	2.70	30 \times 30	2.70			820	22 \times 50	1.80	25 \times 40	1.80	30 \times 30	1.80		
2200			25 \times 45	3.20	30 \times 35	3.20			1000			25 \times 45	2.10	30 \times 35	2.10	35 \times 30	2.10
2700			25 \times 50	3.65	30 \times 40	3.65	35 \times 30	3.65	1200			25 \times 50	2.35	30 \times 40	2.35	35 \times 35	2.35
3300					30 \times 45	4.05	35 \times 35	4.05	1500					30 \times 45	2.80	35 \times 40	2.80
3900					30 \times 50	4.65	35 \times 40	4.65	1800					30 \times 50	3.10	35 \times 45	3.10
4700							35 \times 45	5.15	2200							35 \times 50	3.90
5600							35 \times 50	5.75									

■ 尺寸一覽表，額定紋波電流一覽表 STANDARD SIZE, RATED RIPPLE CURRENT

Size ϕ D \times L(mm), Ripple Current (A r.m.s./105°C, 120 Hz)

額定電壓 WV(V.DC)	200 (2D)								額定電壓 WV(V.DC)	250 (2E)							
	ϕ 22		ϕ 25		ϕ 30		ϕ 35			ϕ 22		ϕ 25		ϕ 30		ϕ 35	
	Size	Ripple	Size	Ripple	Size	Ripple	Size	Ripple		Size	Ripple	Size	Ripple	Size	Ripple	Size	Ripple
330	22 \times 30	1.05							220	22 \times 30	0.90						
390	22 \times 35	1.25							270	22 \times 35	1.05						
470	22 \times 40	1.45	25 \times 30	1.45					330	22 \times 40	1.20	25 \times 30	1.20				
560	22 \times 45	1.65	25 \times 35	1.65					390	22 \times 45	1.40	25 \times 35	1.40				
680	22 \times 50	1.90	25 \times 40	1.90	30 \times 30	1.90			470	22 \times 50	1.60	25 \times 40	1.60	30 \times 30	1.60		
820			25 \times 45	2.20	30 \times 35	2.20			560			25 \times 45	1.90	30 \times 35	1.90		
1000			25 \times 50	2.50	30 \times 40	2.50	35 \times 30	2.50	680			25 \times 50	2.10	30 \times 40	2.10	35 \times 30	2.10
1200					30 \times 45	2.90	35 \times 35	2.90	820					30 \times 45	2.40	35 \times 35	2.40
1500					30 \times 50	3.30	35 \times 40	3.30	1000					30 \times 50	2.80	35 \times 40	2.80
1800							35 \times 50	4.00	1200							35 \times 45	3.30

額定電壓 WV(V.DC)	350 (2V)								額定電壓 WV(V.DC)	400 (2G)							
	ϕ 22		ϕ 25		ϕ 30		ϕ 35			ϕ 22		ϕ 25		ϕ 30		ϕ 35	
	Size	Ripple	Size	Ripple	Size	Ripple	Size	Ripple		Size	Ripple	Size	Ripple	Size	Ripple	Size	Ripple
120	22 \times 30	0.60							120	22 \times 30	0.60						
180	22 \times 40	0.80	25 \times 30	0.80					150	22 \times 35	0.70						
220	22 \times 45	0.95	25 \times 35	0.95					180	22 \times 40	0.80	25 \times 30	0.80				
270	22 \times 50	1.10	25 \times 40	1.10	30 \times 30	1.10			220	22 \times 45	0.95	25 \times 35	0.95				
330			25 \times 45	1.25	30 \times 35	1.25			270	22 \times 50	1.05	25 \times 40	1.05				
390			25 \times 50	1.40	30 \times 40	1.40	35 \times 30	1.40	330			25 \times 45	1.20	30 \times 35	1.20		
470					30 \times 45	1.65	35 \times 35	1.65	390			25 \times 50	1.40	30 \times 40	1.40		
560					30 \times 50	1.90	35 \times 40	1.90	470					30 \times 45	1.60	35 \times 35	1.60
680							35 \times 45	2.00	560					30 \times 50	1.85	35 \times 40	1.85
820							35 \times 50	2.50	680							35 \times 45	2.00
									820							35 \times 50	2.50

額定電壓 WV(V.DC)	450 (2W)							
	ϕ 22		ϕ 25		ϕ 30		ϕ 35	
	Size	Ripple	Size	Ripple	Size	Ripple	Size	Ripple
100	22 \times 30	0.55						
120	22 \times 35	0.60	25 \times 30	0.70				
150	22 \times 40	0.70	25 \times 35	0.75				
180	22 \times 50	0.90	25 \times 40	0.90	30 \times 30	0.90		
220			25 \times 45	1.00	30 \times 35	1.00		
270			25 \times 50	1.15	30 \times 40	1.15	35 \times 30	1.15
330					30 \times 45	1.40	35 \times 35	1.40
390					30 \times 50	1.60	35 \times 40	1.60
470							35 \times 45	1.80
560							35 \times 50	2.10